

Date Created: 01/31/19

Bottle Data Sheet

16oz HDPE Natural Dairy Round

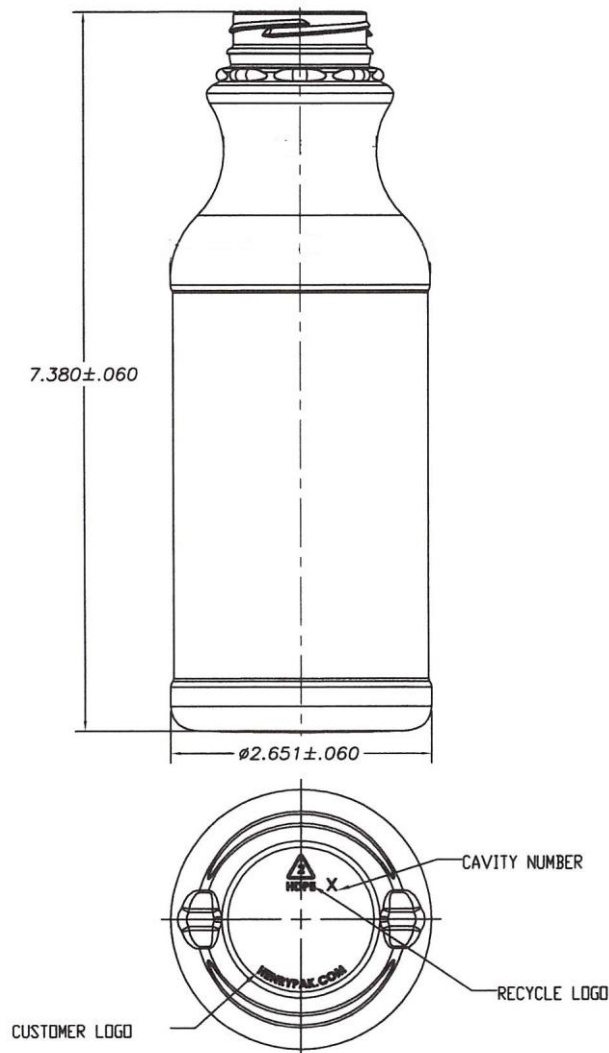

ARCH # 045226-0200

MOLD # 17227 (8 Cavity)

HOUSE RESIN MATERIAL: Marlex HHM 5502BN

OVERFLOW CAPACITY: 480.0 ± 11.0ml

HEIGHT: 7.380 ± 0.060 Inch

WEIGHT: 34.0 ± 2.0 g

DIAMETER: 2.651 ± 0.060 Inch

NECK FINISH: 3 LEAD CLOSURE 358 DBJ

BOTTLE PER BOX: 162

BOTTLE PER PALLET: 3,240

BOTTLE PER 53' TRUCK: 87,480

PALLET WEIGHT: 345 lbs.

STOCK COLORS: Natural